

# PCE<sup>®</sup>

---

## UPS SYSTEMS



# XPI

## ■ USER'S MANUAL ■

For Models  
XPI-500VA ~ XPI-2000VA

# **IMPORTANT SAFETY INSTRUCTIONS**

## **SAVE THESE INSTRUCTIONS**

Before installing XPI 500/1000/2000VA, please read the following information carefully and save this manual for further reference. Disregarding of these safety notes may endanger life or health, as well as the function of the equipment. Special attention must be paid to the CAUTION and WARNING statements in this manual.

### **CAUTION**

- To reduce risk of injury, charge ONLY lead-acid type rechargeable batteries. Other types of batteries may cause damage and injury.
- DO NOT operate the XPI if it has been dropped or damaged in any way.
- DO NOT expose XPI to rain, snow or liquids of any type. XPI is designed for indoor installation only.
- NEVER charge a frozen battery.
- DO NOT obstruct the ventilation openings.
- Risk of electric shock Heat-sinks is live. Disconnect the AC sources and the DC source from this unit before servicing.
- Risk of electric shock. This unit receives power from more than one source. Disconnect the AC sources and the DC source from this unit before servicing.
- Do not remove cover. No user serviceable parts inside. Refer servicing to qualified service personnel.
- The sum of the leakage current of the XPI and the connected equipment should not exceed 3.5mA.
- Risk of explosion if battery is incorrectly connected or replaced.

### **WARNING**

- Provide adequate ventilation from the battery compartment. The battery enclosure should be designed to prevent accumulation and concentration of hydrogen gas at the top of the compartment.
- Input/output AC wiring and battery cables must be rated for 75°C or higher. Using cables diameter, please refer to appendix A, according to different models. The inner diameter of the copper ring terminal which is used to connect battery cables to XPI DC terminals should be no less than 6mm.
- For battery installation and maintenance: read the battery manufacturer's installation and maintenance instructions prior to operating.

### **PERSONAL PRECAUTIONS**

- Have plenty of fresh water and soap nearby in case battery acid contacts skin, clothing, or eyes.
- Avoid touching eyes while working near batteries.

- NEVER smoke or allow a spark or flame in the near vicinity of a battery.
- Remove personal metal items such as rings, bracelets, necklaces, and watches while working with batteries. Batteries can produce short circuit current high enough to make metal melt, and can cause severe burns.
- If a remote or automatic generator start system is used, disable the automatic starting circuit or disconnect the generator to prevent accident during servicing.

**Table of Contents**

1) INTRODUCTION ..... 4

2) OPERATION & INSTALLATION.....4

3) TECHNICAL SPECIFICATIONS .....8

4) TROUBLESHOOTING ..... 9

5) APPENDIX A ..... 9

## 1) INTRODUCTION

The XPI series is an electronic product that has been designed and built to take low DC voltage power from batteries and convert it to standard AC power like the current you have at home.

The XPI series is a DC-to-AC with auto line-to-battery transfer and integrated charging system, XPI series, powers from AC power and DC source, serving as an extended run UPS. When AC cable is connected to a wall socket, utility power goes to connected equipment(s) and/or charges the battery set via charging system. In UPS mode, the XPI series automatically converts battery energy into AC power for backing up the connected devices.

### Features

- Super efficient, DC to AC conversion, minimizing charging losses
- Input voltage range selection option
- Fully automatic start operation
- High frequency technology
- Compact size and light weight
- Provides critical overload protection
- Eco-friendly & non-polluting (green device)
- Advanced technology optimizes battery life

## 2) OPERATION & INSTALLATION

### Front Panel Controls and LED Indicators

Shown below are the controls and indicator lights on the front panel of XPI series.

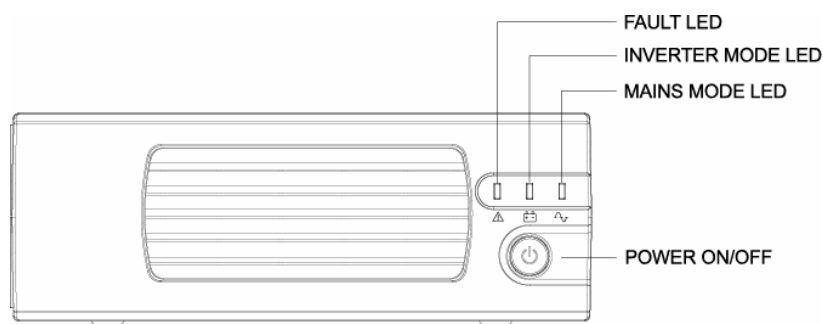

## Rear Panel & Output Description

Shown below are the components on the rear panel of XPI series.

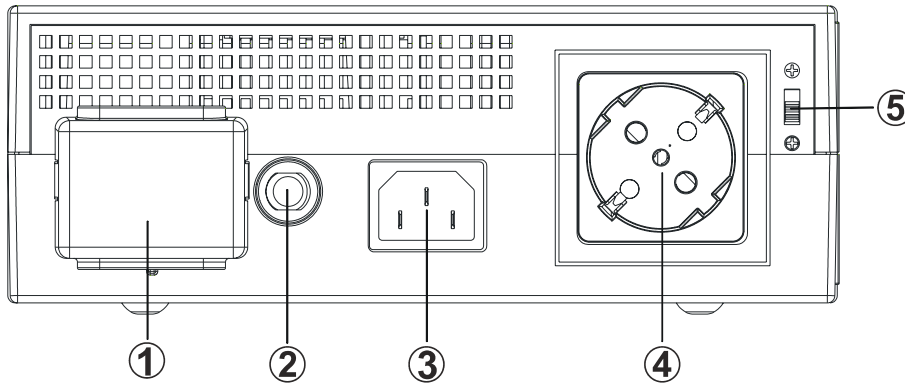

1. DC Input Connector (Battery Terminal)
2. Input Protector
3. AC Input
4. Output Receptacle(s)
5. Input Voltage Range Selector: Input voltage range is defined in specification chapter, and output voltage is the same as input voltage in ‘mains’ mode.
  - A. Select ‘**Narrow**’ setting for general electrical appliance such as tube light, energy saving lamp, TV, Juicer & mixer etc, but it is not suitable to meet high-power motor or inductive load, such as the fridge of 1kW, the motor of 800W, air cooler, PC (having risk of rebooting) and so on. In this mode, the XPI series operating voltage, in ‘mains’ mode, is within 170~280VAC with the same output voltage. The line sensitivity is higher.
  - B. Select “**Wide**” setting to save energy. In this mode the operating range of voltage for the XPI is 90-280VAC, hence the output voltage will be the same as the mains input voltage. The XPI unit in this mode has a lower sensitivity. You can connect and use only for some special load, such as lamp, fan.

## Battery Connection

Step 1- Pinch the bottom of DC input cover and open it.

Step 2- Follow battery polarity guide located near battery terminal. Place the battery cable ring terminal over XPI’s battery terminal. Tighten the M5 nut. Do not place anything between the flat part of battery terminal and the battery cable ring terminal, since overheating may occur.

**Caution!** DO NOT place anything between battery cable ring terminals and battery terminals. The terminal stud is not designed to carry current. Apply anti-oxidant paste to terminals after terminals have been torqued.

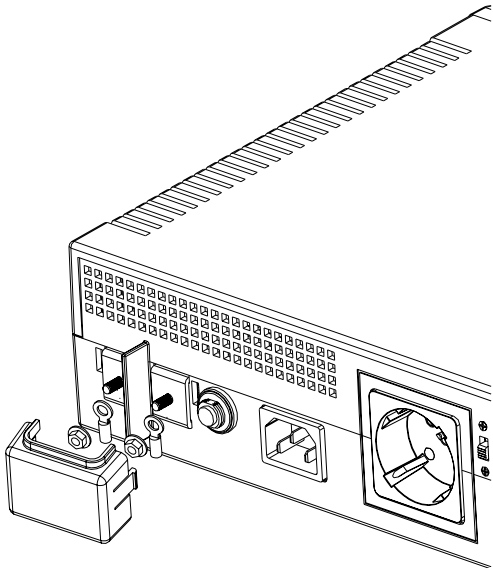

Battery Cable Connection to XPI 500/1000/1500/2000VA

Step 3- Connect battery cables to your batteries  
 The battery must be wired to match the units DC input voltage specifications (12V for XPI 500/1000VA, 24V for XPI 2000VA)

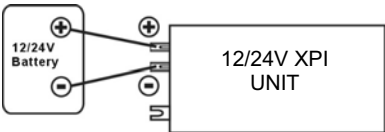

In addition, the batteries can be wired to provide additional run time. The various wiring configurations are as follows:

- **Series Connection:** Wiring batteries in “series” increases the total output voltage. This voltage must match the DC voltage requirements of the XPI unit, or it may damage both the XPI unit and/or the batteries.

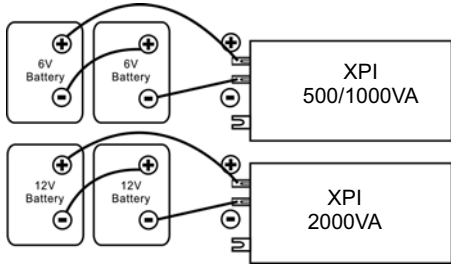

- **Series Connection:** Wiring batteries in “series” increases the total output voltage. This voltage must match the DC voltage requirements of the XPI unit, or it may damage both the XPI unit and/or the batteries.

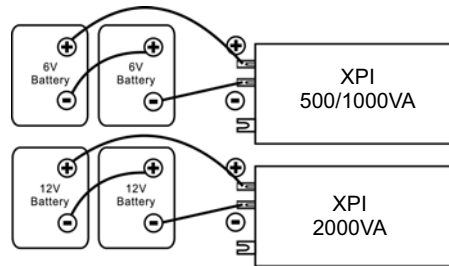

- **Parallel Connection:** Wiring batteries in “parallel” increases the total run time, the batteries can operate the AC loads. The more batteries connected in parallel the longer run time the loads can be powered from the XPI unit.

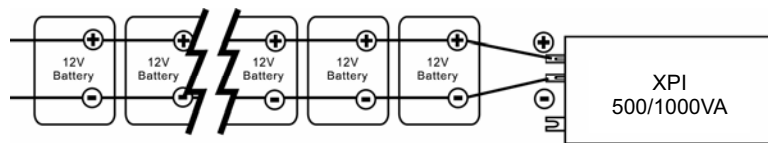

- **Series-Parallel Connection:** “Series-parallel” configuration increases both the battery voltage (to match the DC requirements of XPI unit) and run time for operating the AC loads.

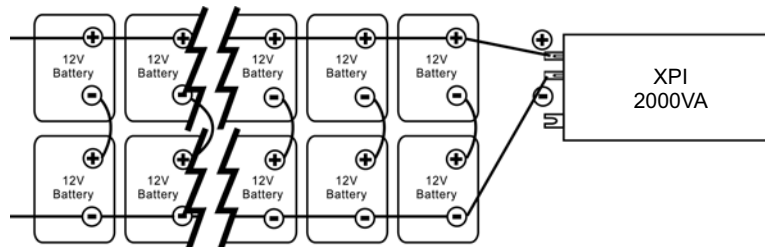

### 3) TECHNICAL SPECIFICATIONS

Model XPI Series		XPI 500	XPI 1000	XPI 2000
Output power with $\cos \varphi = 0.6$		500VA	1000VA	2000VA
		300W	600W	1200W
<b>Input</b>	Voltage	220V/230V/240V		
	Voltage Range (V)	Narrow                      Wide 170V~280V                  90V~280V		
	Frequency Range	50 or 60Hz +/-10% (auto sensing)		
<b>Output</b>	Voltage	230V +10% / -18%		
	Frequency (Back up Mode)	50 or 60Hz +/-0.5Hz		
	Efficiency - AC to AC - DC to AC	>95% >80%		
	Wave Form	Modified sinewave		
	Transfer Time	7ms typical		
<b>Protection</b>	Full Protection Range	Deep discharge, overcharge, over voltage, under voltage, short circuit, overload, battery short		
<b>System Display Warning</b>	Line Mode	Green LED blinks or lights steadily		
	Battery Mode	Yellow LED lights		
	Low battery voltage at batt. mode	Beeping sound every 2 seconds		
	Overload	Red LED blinks or lights steadily and beeping sound every 0.5 sec		
	Fault	Red LED blinks or lights steadily and continuous beeping sound		
<b>Battery</b>	DC Voltage	12VDC		24VDC
<b>Charger</b>	Charging Voltage	13.7V +/-0.2		27.4V +/-0.4
	Charging Current	10A max		
	Over Charge Protection	16V +/-0.4		32V +/-0.8
<b>Physical</b>	Net Weight kg (lbs)	2(4.4)	2.3(5.06)	2.5(5.5)
	Dimensions WxDxH mm (inch)	242x249x80 (9.5"x9.8"x3.15")		
<b>Environment</b>	Ambient operation	0-95% humidity, 0-40°C		
	Audible noise	<35dBA (1 meter from surface)		
<b>Standards</b>	Performance	EN 62040-1-1:2003		
	Safety	EN 60950-1:2001(RD)		
	EMC (EMS/EMI)	EN62040-2; EN55022 CLASS A; EN61000-3-2; EN61000-3-3 IEC 61000-4-2/-3/-4/-5; IEC 61000-2-2; CISPR 22		
	Design, production, services	ISO 9001		
	Environment Marking & Certifications	ISO 14001 certified company CE		

[www.pceups.com](http://www.pceups.com)

## 4) TROUBLESHOOTING

<b>Problem</b>	<b>Possible Causes</b>	<b>Remedy</b>
No LED display	1. Battery Weak	1. Re-charge battery
	2. Battery defective	2. Battery replacement
	3. Power switch is not pressed	3. Press and hold power switch
Mains normal but works in inverter mode	1. AC Input missing	1. Check AC input connection
	2. Input protector is effective	2. Reset the input protector
Alarm buzzer beeps continuously	Overload	1. Verify that the load matches the capability specified in the specs
Back up time is shortened	Overload	1. Remove some non-critical load
	Battery voltage is too low	2. Charge battery for 8 hours or more

## 5) APPENDIX A

<b>Models</b>	<b>Input/output cables (gauge copper wire)</b>	<b>Battery cables (gauge copper wire)</b>
500VA/12VDC	At least 20AWG	At least 10AWG
1000VA/12VDC	At least 20AWG	At least 8AWG
2000VA/24VDC	At least 18AWG	At least 8AWG

## Service & Technical Notes

1.

---

---

2.

---

---

3.

---

---

4.

---

---

5.

---

---

6.

---

---

7.

---

---

8.

---

---

9.

---

---

10.

---

---

# WWW.PCEUPS.COM

Please visit our website at [www.pceups.com](http://www.pceups.com) for updates and additional product information.

**North America**

PCE UPS SYSTEMS Inc.  
4805 Colombo Cres.  
Mississauga, Ontario  
Canada

**Europe**

PCE – Pronergy SA  
5 Rue Ampere  
91380, Chilly Mazarin  
France

**Middle East**

PCE UPS SYSTEMS FZCO  
LOB 16 #236, Jebel Ali Free Zone  
P.O.Box 261840, Dubai  
UAE