

Voltage Stabilizer

PVS Series 10KVA~1500KVA

- Intelligent logic regulation circuit
- Electronics double circuitry switch design
- Various input voltage range as per the fluctuations
- Works over wide input frequency range
- Wide Load Applicability
- Negligible losses in full buck/boost condition, high efficiency stabilizer
- Undistorted output voltage, unaffected by load power factor variations
- Precise control of output voltage with stepless adjustment
- Fast correction speed
- Innovative panel design
- Cutting-edge protective circuitry
- Double overload protection
- Overvoltage and undervoltage protection
- Phase Loss & Phase Disorder* protection
- Surge Suppressor/LC filter/EMI filter/Isolation transformer* for pure power
- Automatic mode of operation
- Maintenance Bypass Switch*

* For Optional Features



PCE[®]
UPS SYSTEMS

**YOUR ULTIMATE
POWER PROTECTION PARTNER**

www.pceups.com

Intelligently Logic Regulation

The powerful PVS series can completely adjust the regulation speed and regulation range in accordance with power's variation and the load character on the spot by a precise and unique motor to gain the most satisfactory power regulation required.

Separate Regulators Design

Whenever AC power encounters three phase unbalanced, non linear power or heavy load, the separate regulators will still maintain its accurate output.

Innovative Panel Design

To renovate the traditional meter reading, PVS series provides user a very clear reading only by checking the indicators' colors to realize the status (normal or abnormal). The green indicator shows abnormal status.

All Module Design

All the technical design inside PVS series is of module designed and separately assembled, components used on PCB are very stringently quality controlled and tested by computerized ICT satisfactory quality reliability.

Self-Detect Function Design

The self-Detect result is displayed by light indicators providing immediate and exact malfunction information to users making maintenance more easy and efficient.

Powerful Overload Capability

The PVS series is specially designed to withstand 150% overload of its nominal load while maintaining its output voltage.

Start Over Voltage Protection

Whether it is switched on or recovered from outage, the Start Over Voltage Protection will always start from low voltage to protect the load side equipment.

Humanized Anti-Mistake Circuit Design

To prevent from inappropriate operation that can cause AC output to switch ON or OFF, the PVS series has a very delicate electronic double-circuit control design, one must simultaneously push two ONs or two OFFs to start or shutdown the PVS.



Big Range High/Low Voltage Protection

Whatever the load side is, heavy load equipment or precise equipment, even if there is a very massive power variation, the PVS series has a very special feature design of Various/Multi/Big range select to preset the most appropriate and precise adjustment in accordance with the load requirement.

Phase Failure Protection

If there is any failure within three phase power, PVS series will immediately detect and display the failure, it will also trip off to protect the load side equipment.

Instant Trip Device

This Instant Trip Device will always trip before AC recovers from an instant black-out, it features a reset function ensuring the operation of a stable power again while AC power is back to normal. The purpose of this device is to protect the load equipment from being damaged by any abnormal high voltage condition.

Bypass Device

The PVS series can provide High/Low voltage protection, Phase Failure protection, ect...and all other featured protection when the bypass status is under maintenance or repair.

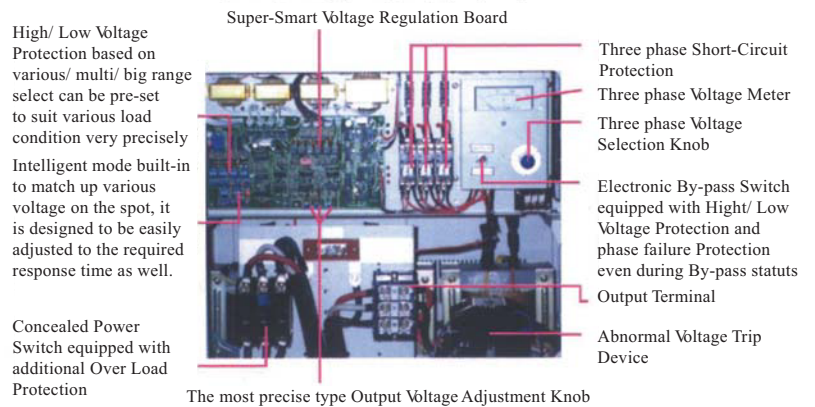
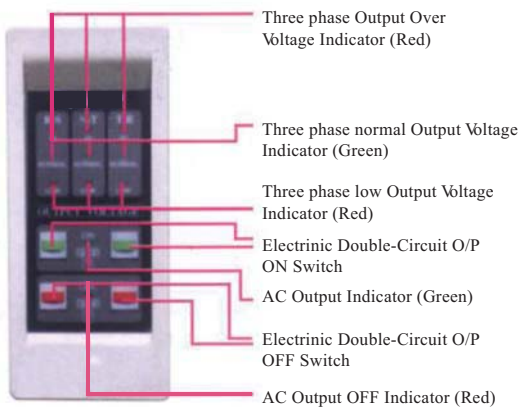

Model PVS		PVS-10	PVS-15	PVS-20	PVS-30	PVS-45	PVS-60	PVS-75	PVS-100	PVS-120	PVS-150	PVS-200	PVS-250	PVS-300							
Capacity with P.F=0.8		10KVA 8kW	15KVA 12kW	20KVA 16kW	30KVA 24kW	45KVA 36kW	60KVA 48kW	75KVA 60kW	100KVA 80kW	120KVA 96kW	150KVA 120kW	200KVA 160kW	250KVA 200kW	300KVA 240kW							
General Specifications	Centralization Function	Centralization of voltage to center value																			
	Mode of Operation	Automatic (no manual adjustment, no up/down push button)																			
	Overall Efficiency	More than 98%																			
	Power factor	0.95-1																			
	Response Time	Voltage stabilized per second is instantaneous (millsec. 0.05 sec)																			
	Voltage Stabilization Time	< 2 second if input voltage is at 100 ± 10% of rated voltage																			
	Voltage Endurance	2000V/1Minute without Puncture																			
	Insulation Resistance	>3MΩ																			
Input	Voltage	220V/380V/415V, 3P3W or 3P4W (Check Models)																			
	Frequency	50Hz-60Hz																			
	Voltage Tolerance	+/-25% of nominal voltage [available +/-20%, +/-30%, +/-35% upon customer request]																			
Output	Voltage	220V/380V/415V Volts , 3P3W or 3P4W (Check Models)																			
	Output Accuracy	+/-0.5% to +/-4% (adjustable), factory set at 1%, capable of central function																			
	Frequency	50Hz-60Hz																			
	Voltage Regulation Mode	Stepless Adjustment																			
Models Configuration	Wave Form Distortion	Virtually Nil																			
		I/P Voltage			O/P Voltage			I/P Voltage			O/P Voltage										
	Models																				
	X1 (I/P&O/P are the same)	220V			220V			380V			220V										
	X2 (I/P&O/P are the same)	380V			380V			380V			415V										
	X3 (I/P&O/P are the same)	415V			415V			415V			220V										
	X4 (I/P&O/P are different)	220V			380V			415V			380V										
X5 (I/P&O/P are different)	220V			415V			415V			380V											
Protection	High/Low Voltage, Phase Failure, Bypass	Standard feature (can be Various/Multi/Big range pre-set and LED displayed)																			
	Overload	150% for 30 second																			
System Display	Power Indicator, Voltage Indicator, Abnormal Status	Standard Feature																			
	Dimension WxDxH (cm)*	30x59x55			38x78x67			49x99x80			50x100x90			58x100x130			128x66x138			128x82x195	
Physical	Weight (Kg)*	77	90	128	160	240	296	329	516	700	795	990	1015	1240							
	Ambient Temperature	Temperature: 0°C-50°C																			
Environmental conditions	Humidity	Humidity: 0-95% RH																			
	Noise Level	<55dBA																			
	Height	≤1000 meters (above sea level)																			
Standards & Certifications	Performance, Safety, EMC (EMS/EMI), Design, Production, Services, Environment	IEC 61000-4-2/-3/-4/-5/-6/-8/-11, IEC 61000-3-2/-3, IEC62040/2, IS2026/BS171/IEC76, EN55022, EN 50091-1/IEC62040-2, ISO 9001:2000, CE, EN60950																			

* Mentioned units are up to 25% input voltage tolerance. The physical dimensions and weights change according to different values of tolerance

Model PVS		PVS-400	PVS-500	PVS-600	PVS-750	PVS-1000	PVS-1200	PVS-1500	
Capacity with P.F=0.8		400KVA	500KVA	600KVA	750KVA	1000KVA	1200KVA	1500KVA	
		320kW	400kW	480kW	600kW	800kW	960kW	1200kW	
General Specifications	Centralization Function	Centralization of voltage to center value							
	Module Design Type	Twin Module Type for each phase (each module will have half voltage regulation rate)							
	Mode of Operation	Automatic (no manual adjustment, no up/down push botton)							
	Overall Efficiency	More than 98%							
	Power factor	0.95-1							
	Response Time	Voltage stabilized per second is instantaneous (millsec. 0.05 sec)							
	Voltage Stabilization Time	< 2 second if input voltage is at 100 ± 10% of rated voltage							
	Voltage Endurance	2000V/1Minute without Puncture							
Input	Insulation Resistance	>3MΩ							
	Voltage	220V/380V/415V, 3P3W or 3P4W (Check Models)							
	Frequency	50Hz-60Hz							
Output	Voltage Tolerance	+/-25% of nominal voltage [available +/-20%, +/-30%, +/-35% upon customer request]							
	Voltage	220V/380V/415V Volts , 3P3W or 3P4W (Check Models)							
	Output Accuracy	+/-0.5% to +/-4% (adjustable), factory set at 1%, capable of central function							
	Frequency	50Hz-60Hz							
Models Configuration	Voltage Regulation Mode	Stepless Adjustment							
	Wave Form Distortion	Virtually Nil							
		Voltages		Voltages					
	Models	I/P Voltage	O/P Voltage	Models	I/P Voltage	O/P Voltage			
	X1 (I/P&O/P are the same)	220V	220V	X6 (I/P&O/P are different)	380V	220V			
	X2 (I/P&O/P are the same)	380V	380V	X7 (I/P&O/P are different)	380V	415V			
	X3 (I/P&O/P are the same)	415V	415V	X8 (I/P&O/P are different)	415V	220V			
	X4 (I/P&O/P are different)	220V	380V	X9 (I/P&O/P are different)	415V	380V			
	X5 (I/P&O/P are different)	220V	415V						
Protection	High/Low Voltage, Phase Failure, Bypass	Standard feature (can be Various/Multi/Big range pre-set and LED displayed)							
	Overload	150% for 30 second							
System Display	Power Indicator, Voltage Indicator, Abnormal Status	Standard Feature							
Physical	Dimension WxDxH (cm)*	128x82x195	128x82x195	128x82x195	128x120x195	128x120x195	128x150x195	128x150x195	
	Weight (Kg)*	1395	1750	2280	2445	2720	3250	3470	
Environmental conditions	Ambient Temperature	Temperature: 0°C - 50°C							
	Humidity	Humidity: 0 - 95% RH							
	Noise Level	<55dBA							
	Height	< 1000 meters (above sea level)							
Standards & Certifications	Performance, Safety, EMC (EMS/EMI), Design, Production, Services, Environment	IEC 61000-4-2/-3/-4/-5/-6/-8/-11, IEC 61000-3-2/-3, IEC62040/2, IS2026/BS171/IEC76, EN55022, EN 50091-1/IEC62040-2, ISO 9001:2000, CE, EN60950							

* Mentioned units are up to 25% input voltage tolerance. The physical dimensions and weights change according to different values of tolerance

NORTH & SOUTH AMERICA

PCE UPS SYSTEMS Inc.

4805 Colombo Cres.

Mississauga, Ontario

Canada

Tel: +1.905.607.2552

Fax: +1.905.607.9811

EUROPE

PCE – Pronergy SA

5 Rue Ampere

91380, Chilly Mazarin

France

Tel: +33 1 69.19.43.03

Fax: +33 1 69.19.43.01

MIDDLE EAST & AFRICA

PCE UPS SYSTEMS FZCO

LOB 16 #236, Jebel Ali Free Zone

P.O.Box 261840, Dubai

United Arab Emirates

Tel: +971.4.8873908

Tel: +971.4.8873909

www.pceups.com

LFPVS10-1500ENQ209

